

# Experimental Physics 3 - Em-Waves, Optics, Quantum mechanics

---

## Lecture 8

Interference

# Coherence - Spatial Coherence

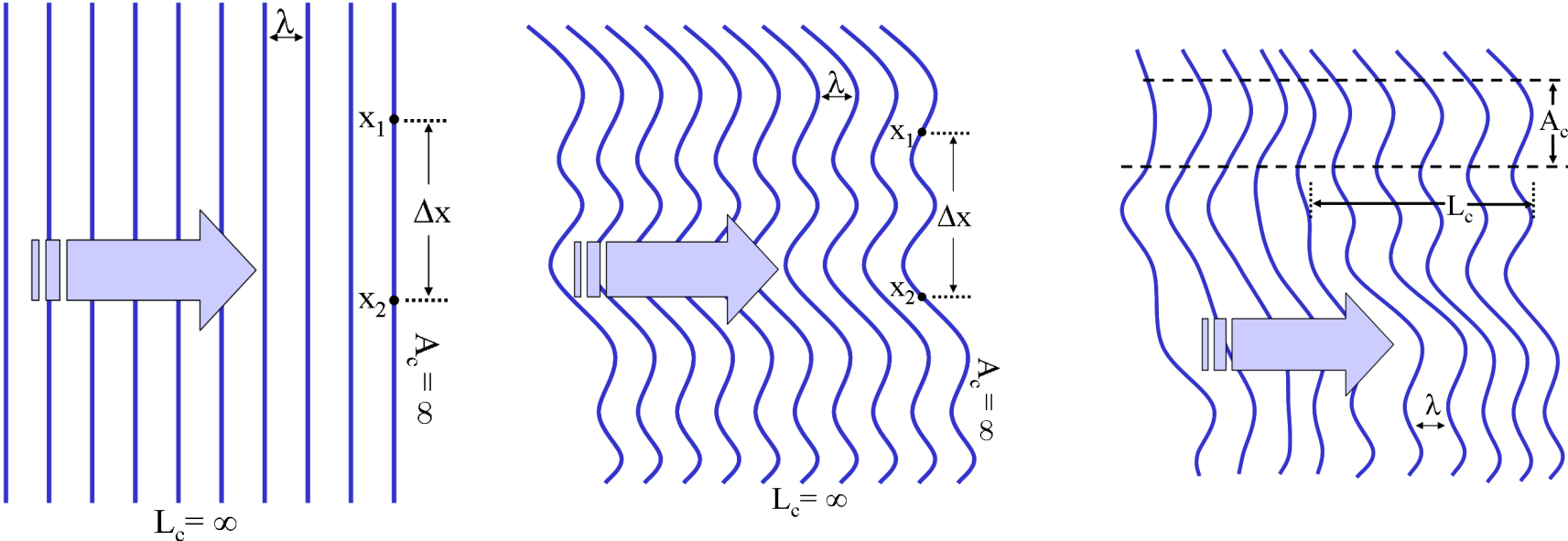

# Coherence - Temporal Coherence

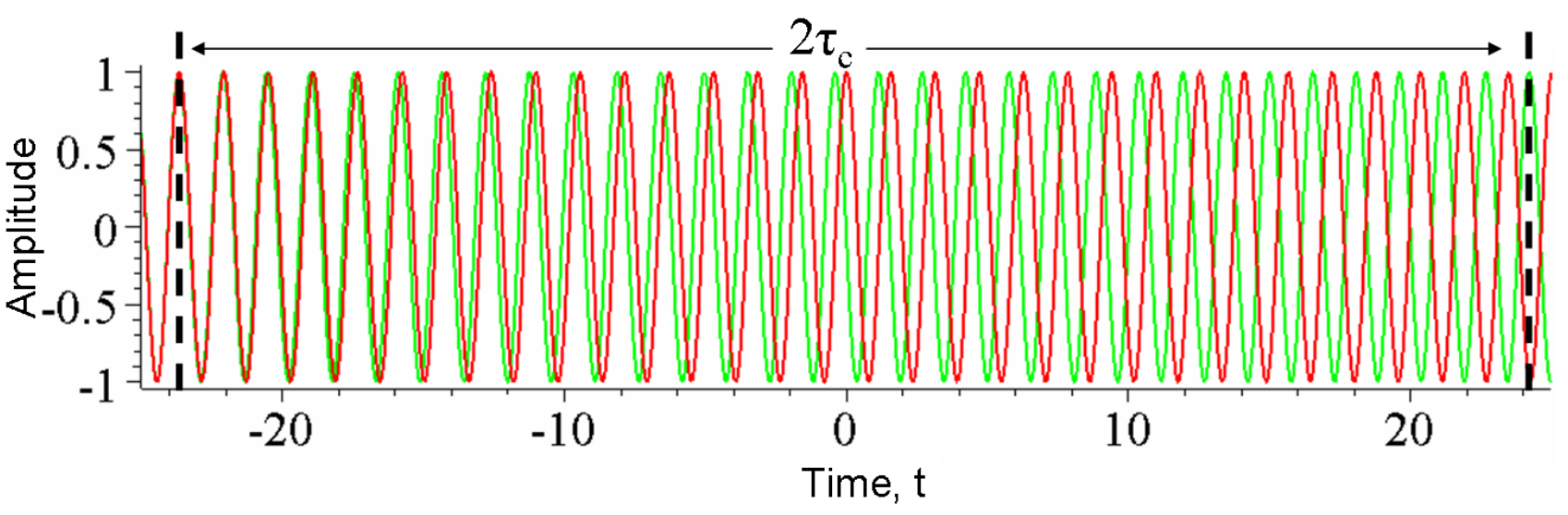
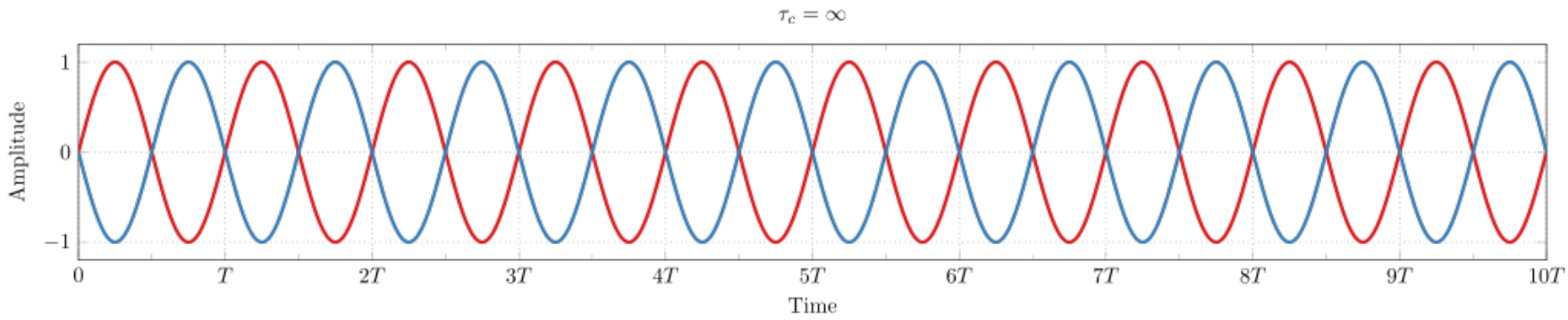

# Interference

---

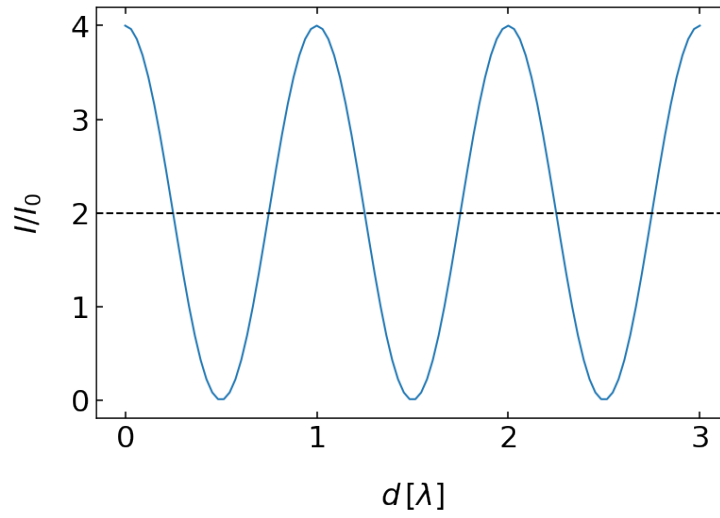
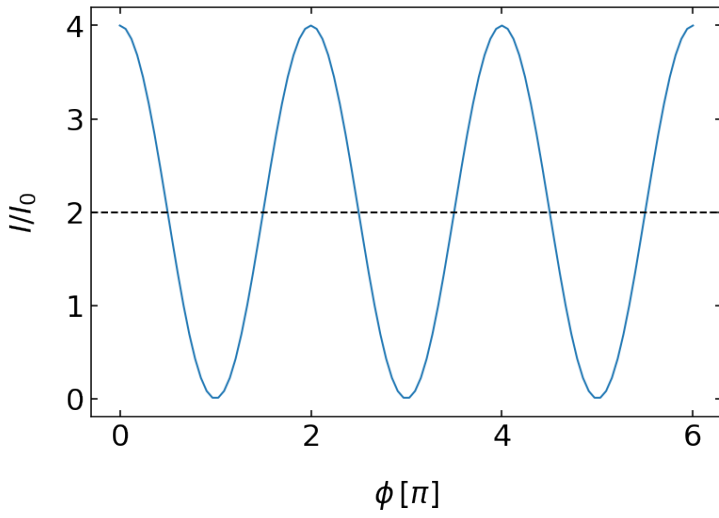

# Interference in Space

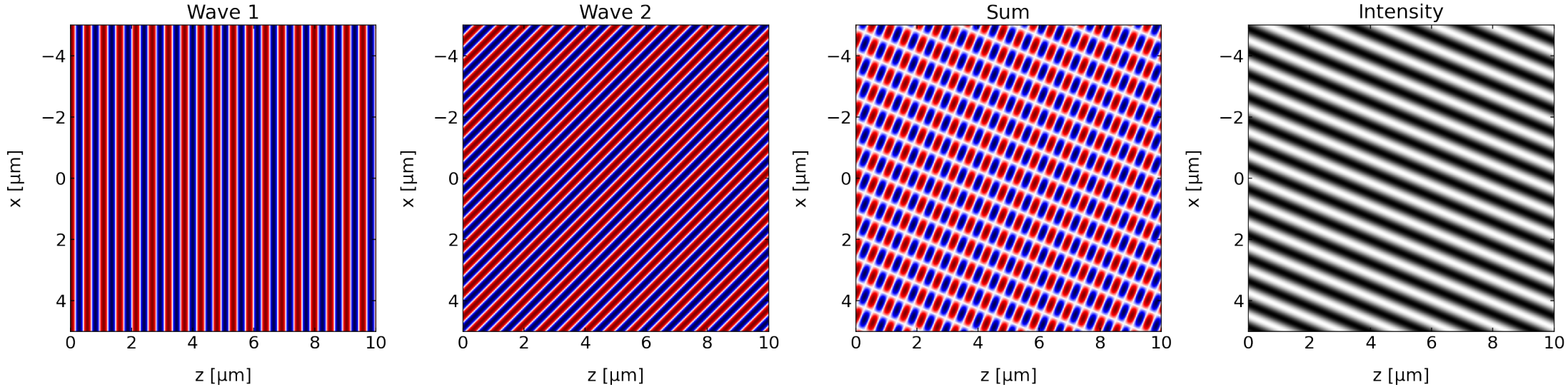

# Interference Between Spherical and Plane Wave

---

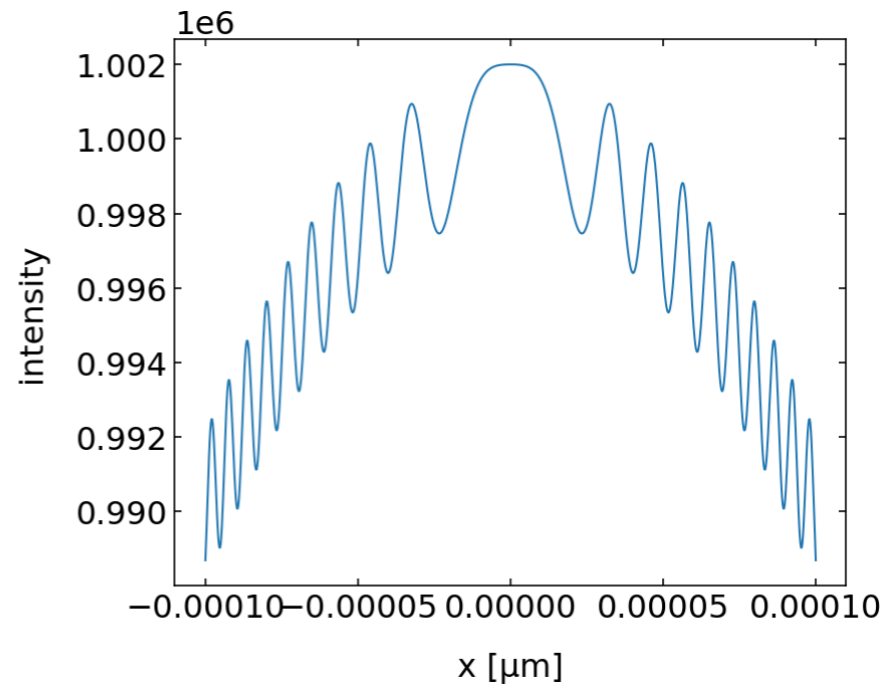
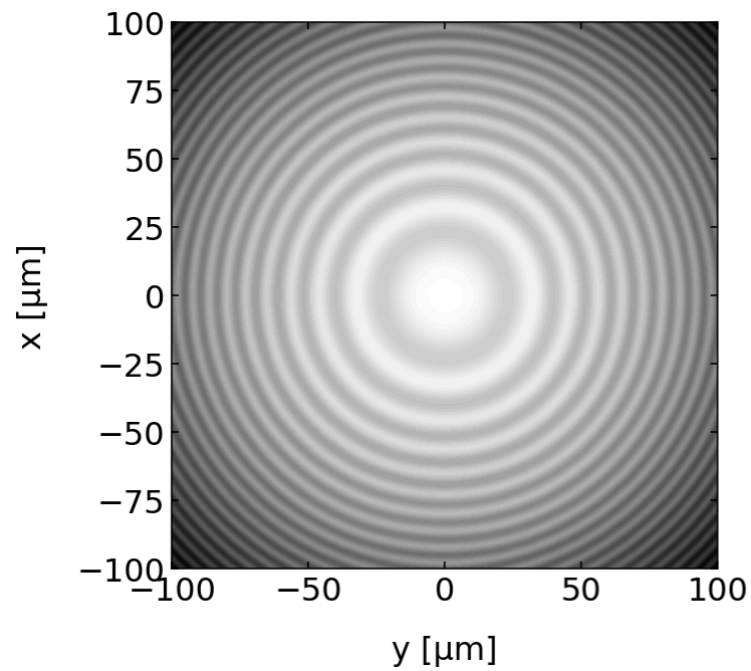

# Interferometers

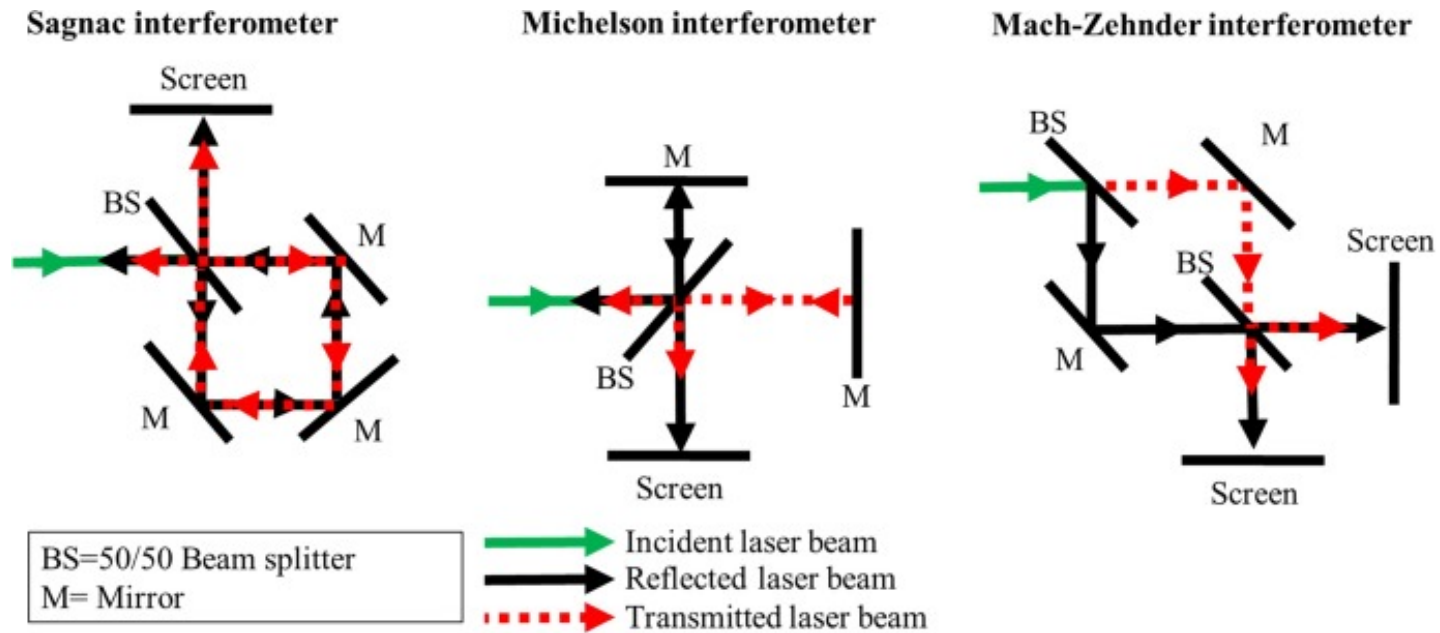



# Holographic microscopy

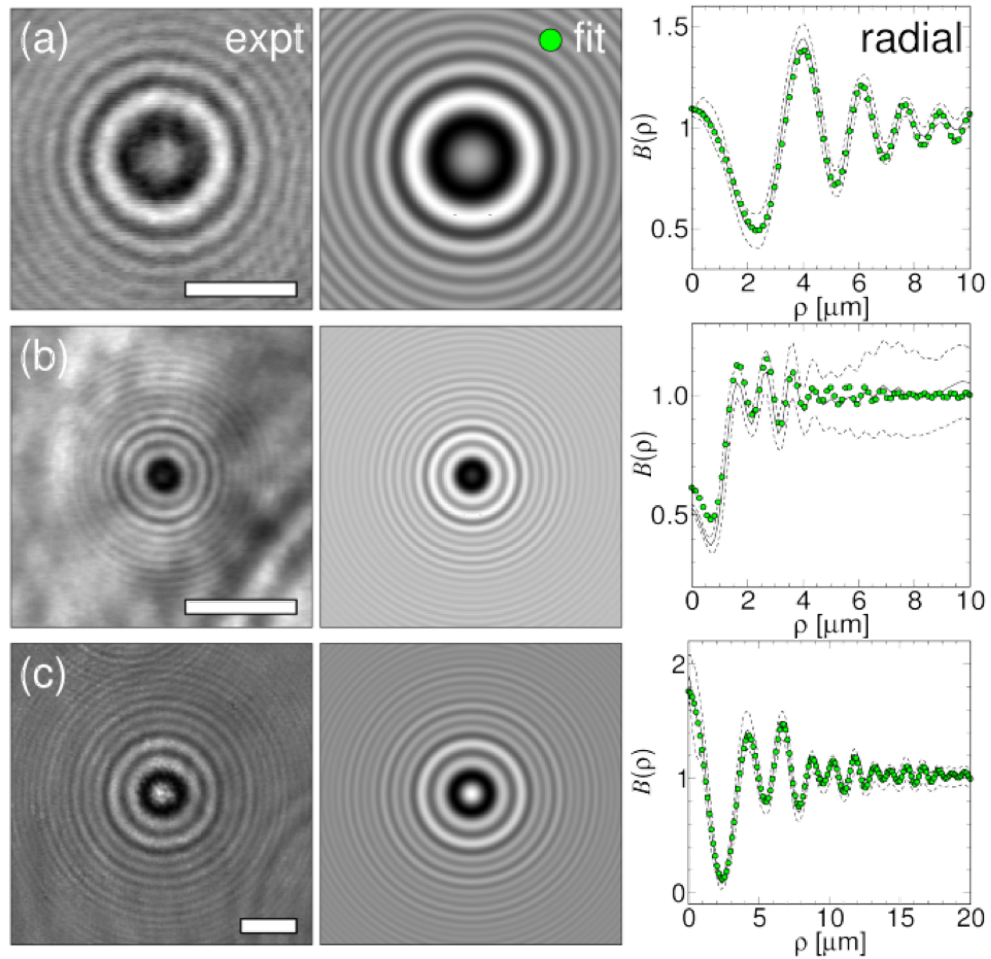
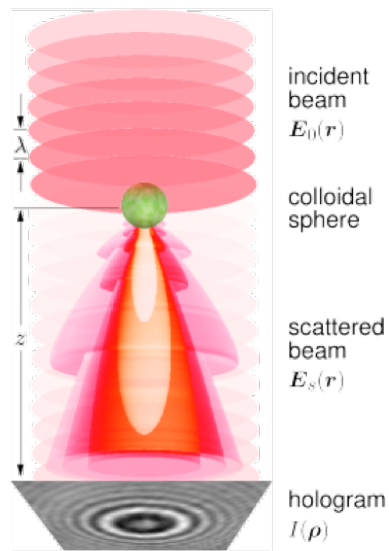

# Interferometric particle detection

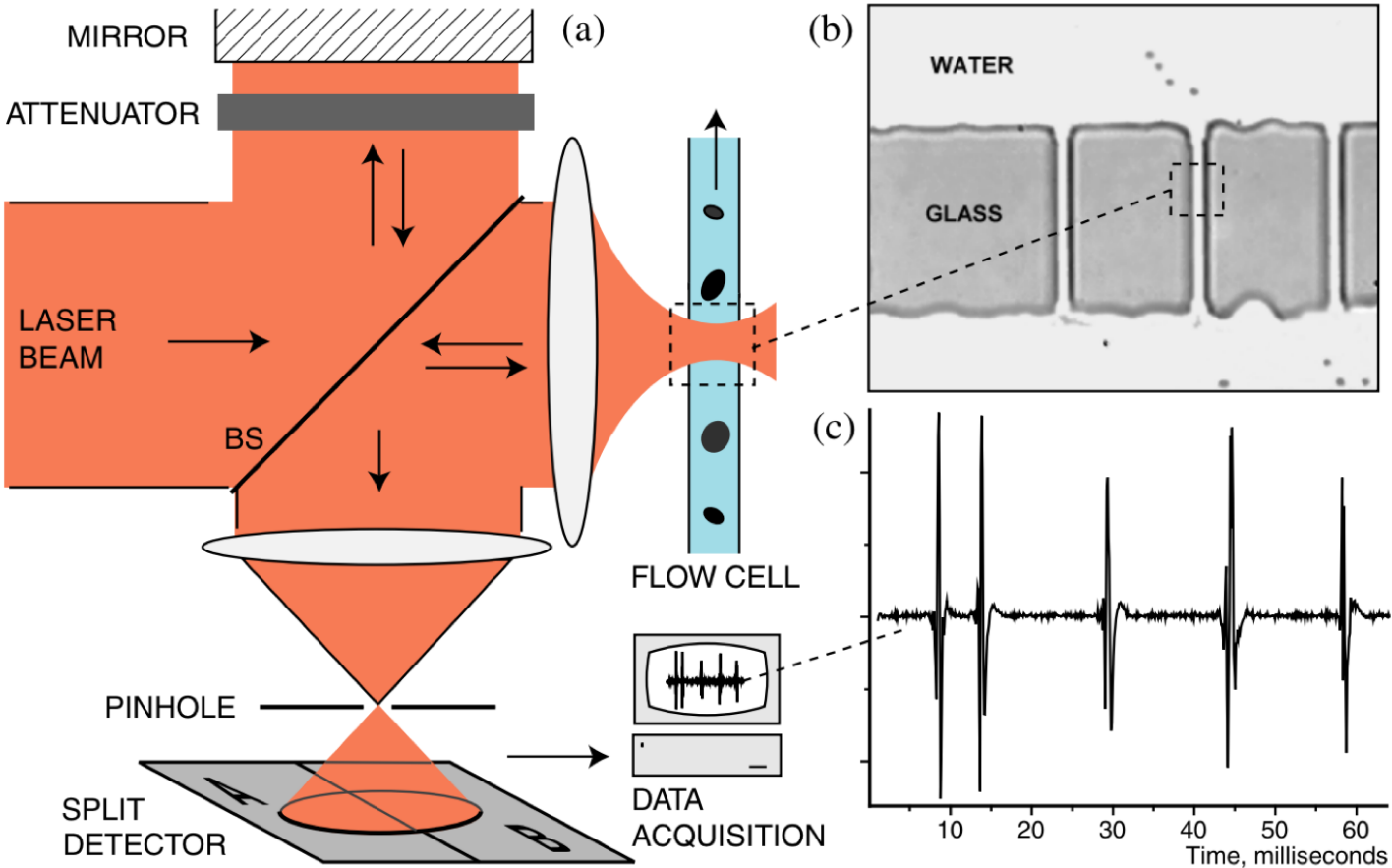

# Optical Coherence Tomography

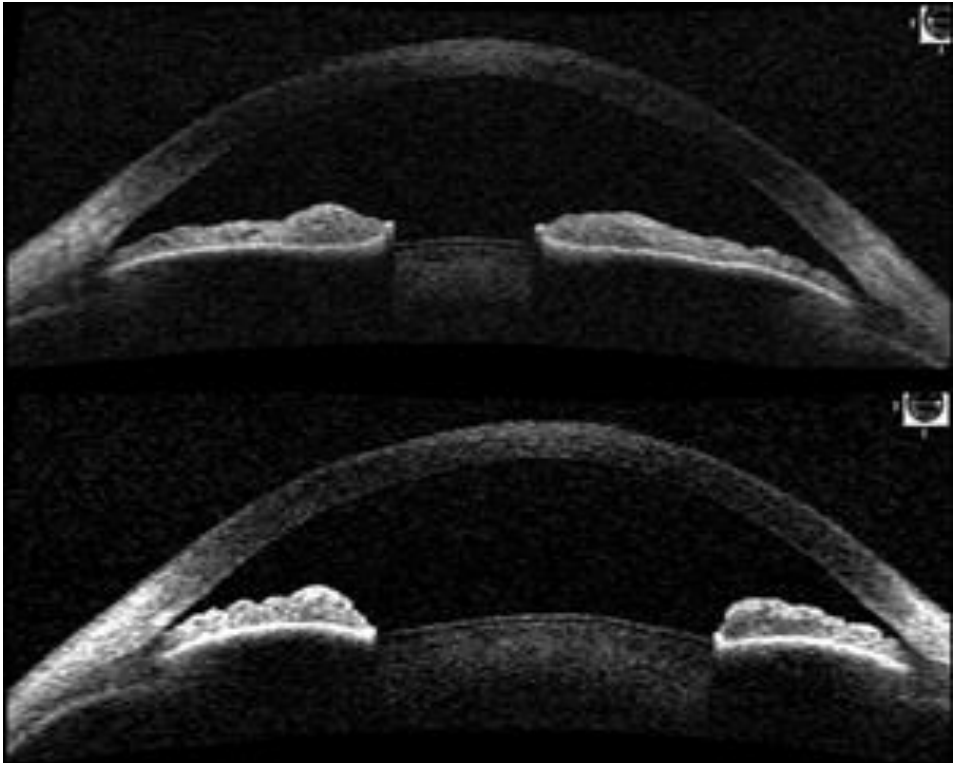
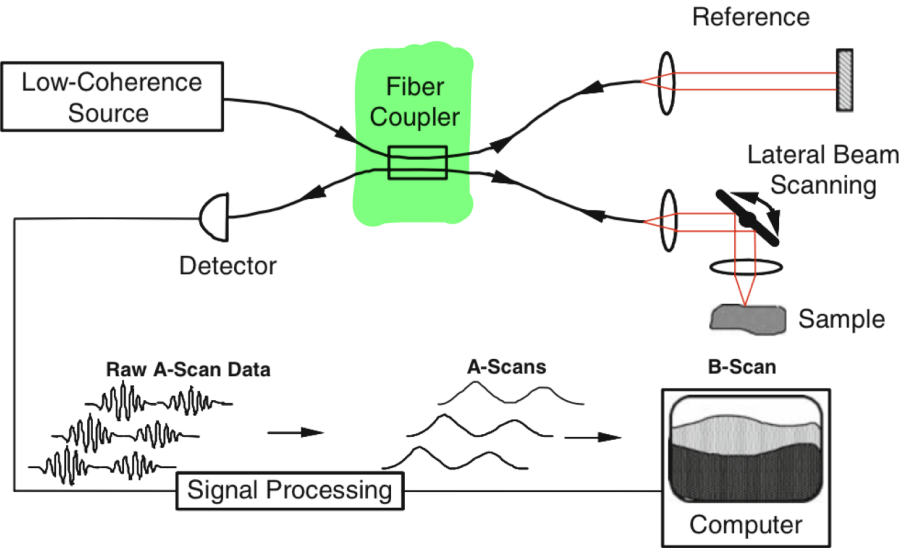

# LIGO - Laser Interferometer Gravitational-Wave Observatory

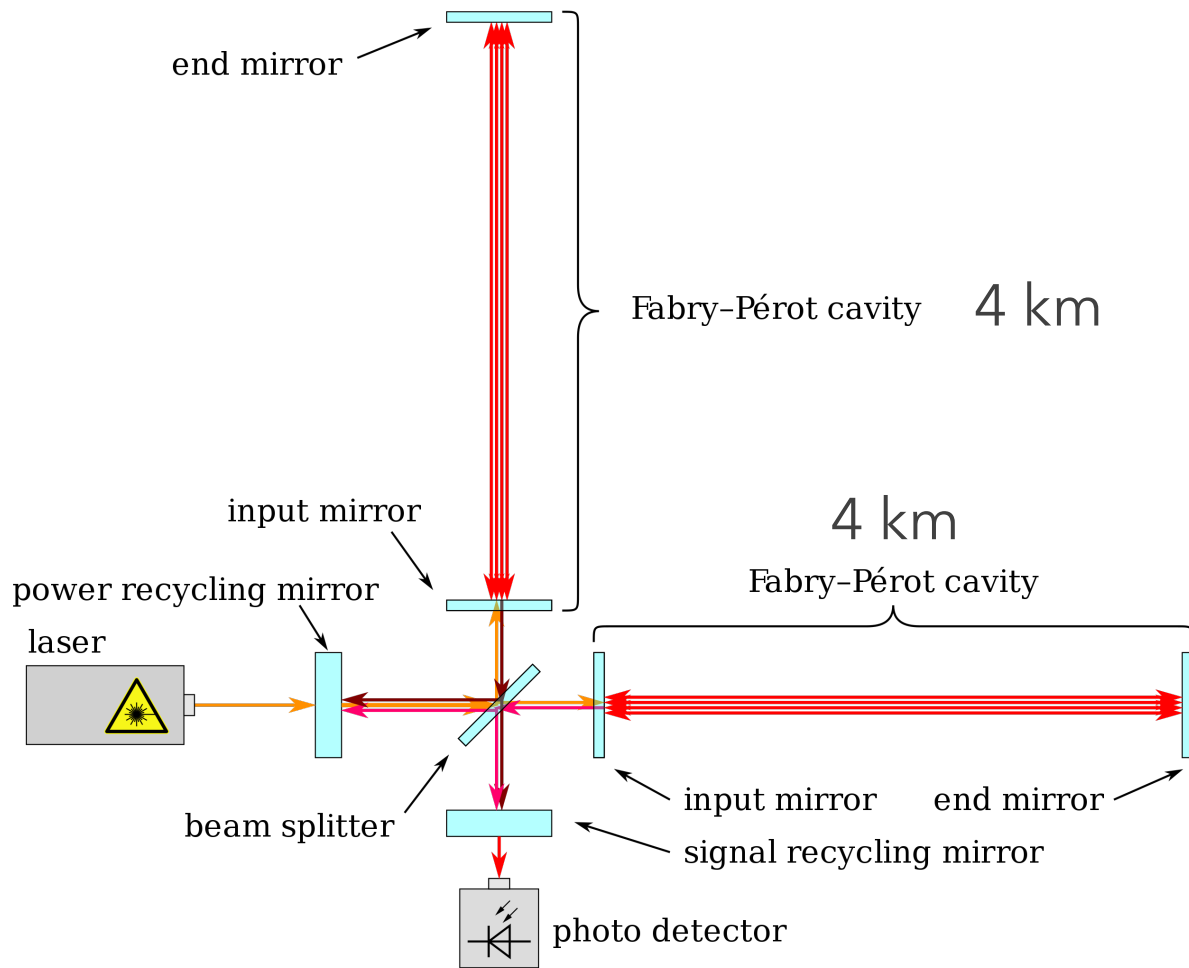

$10^{-22}$  relative length change

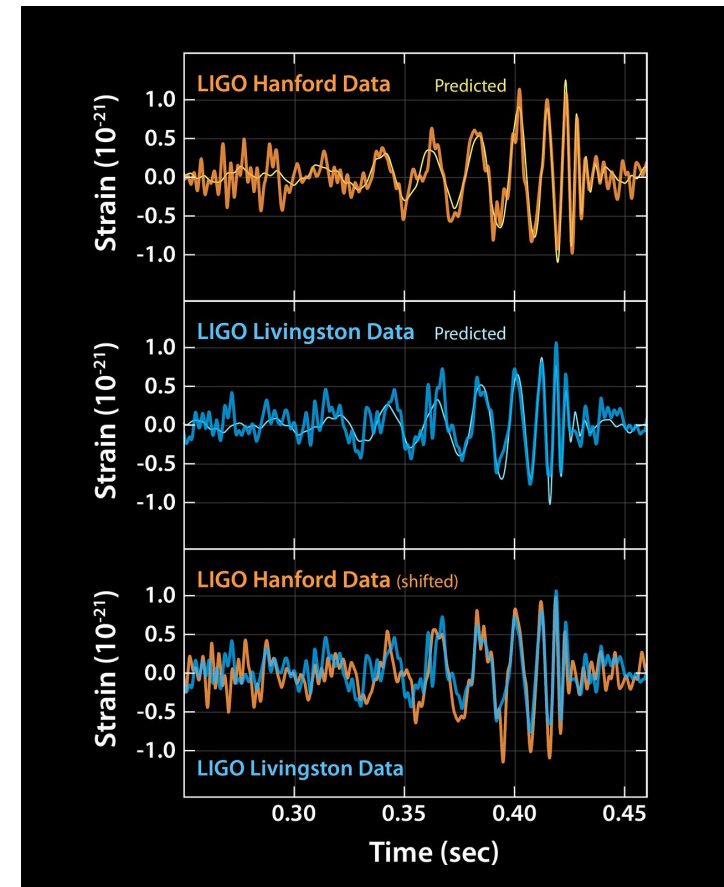

# Thin Film Interference

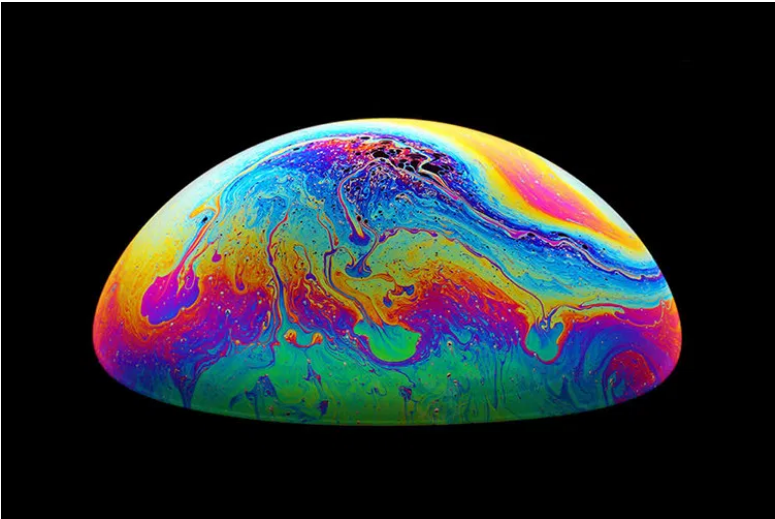
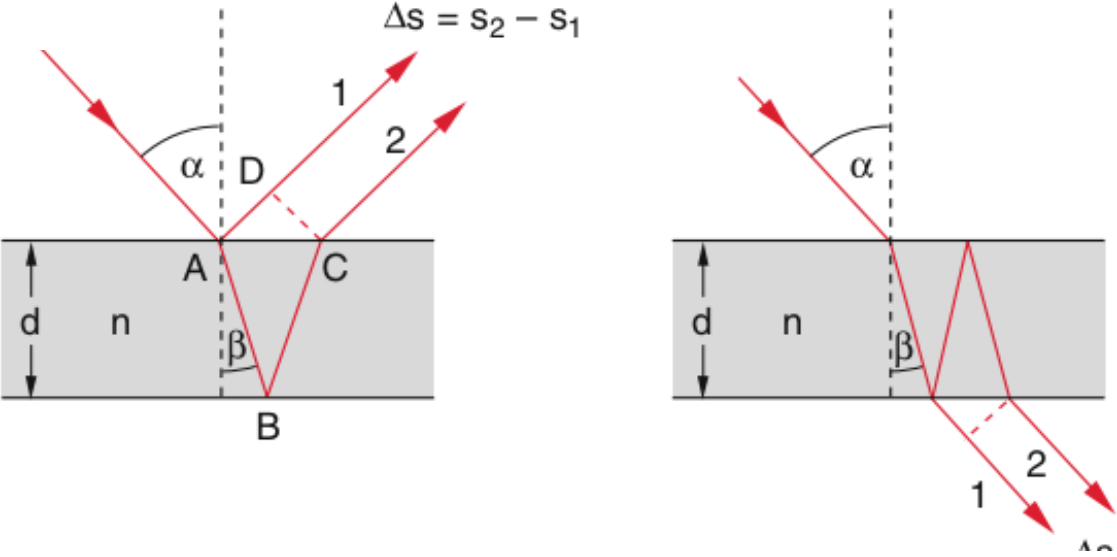

# Newton Black Film - Soap Bubble Challenge

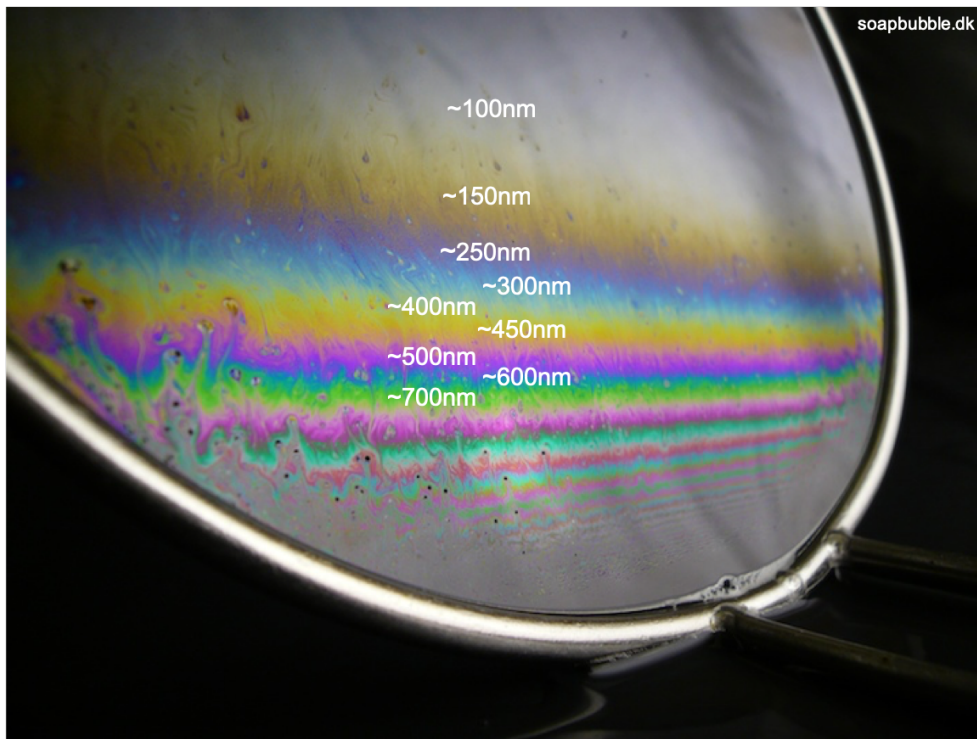

# Multiple Wave Interference - Constant Intensity

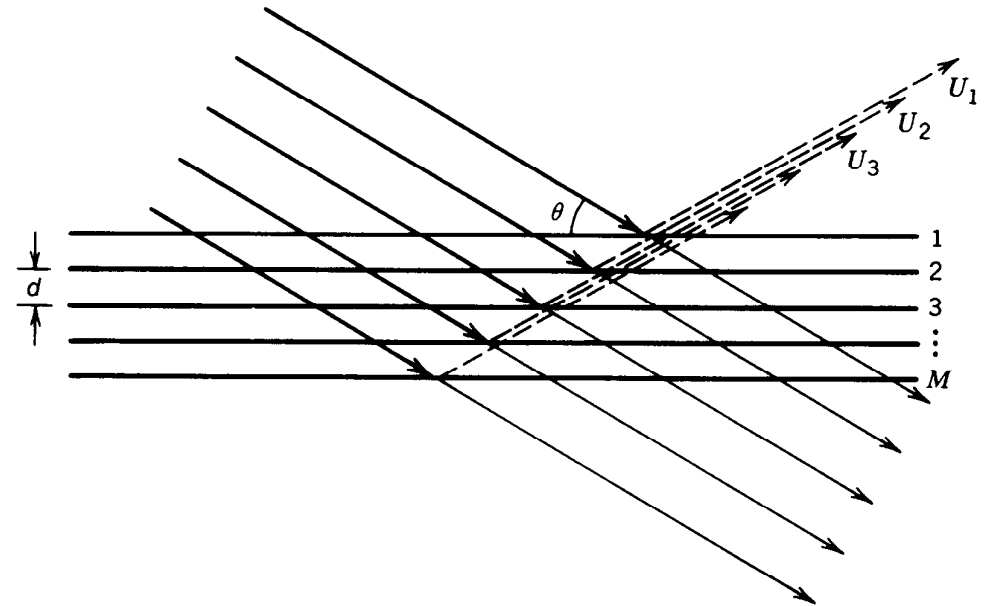
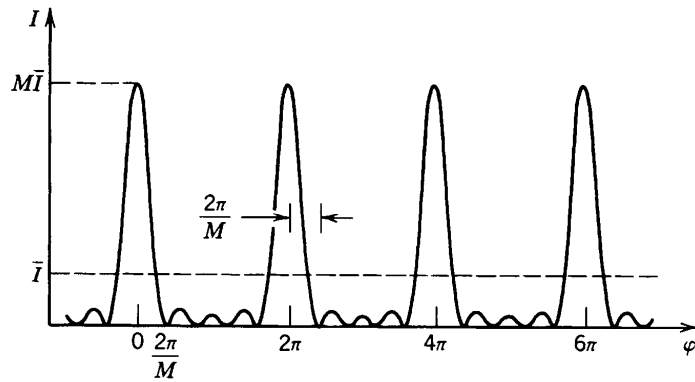
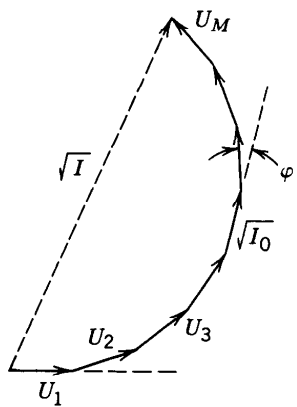

# Multiple Wave Interference - Decaying Intensity

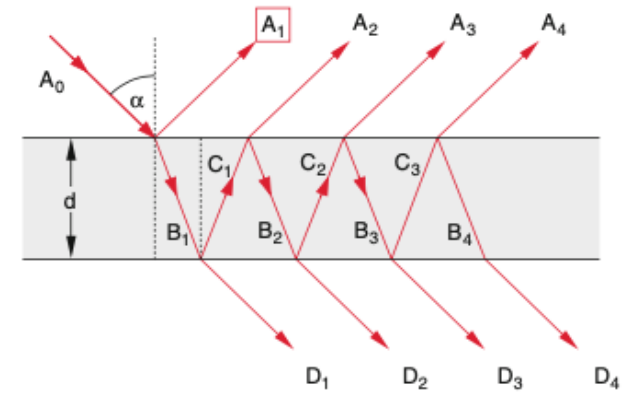
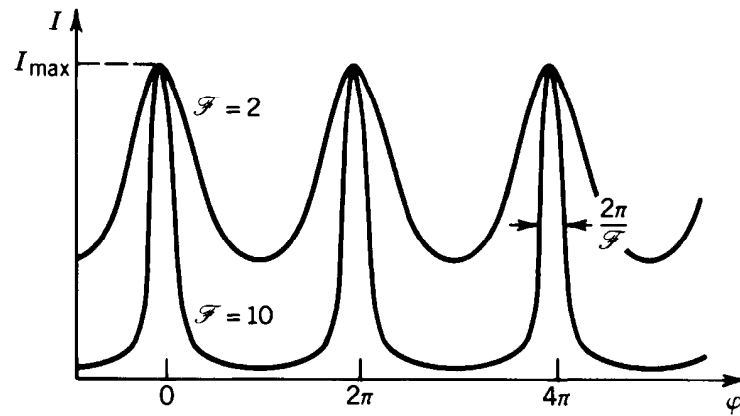
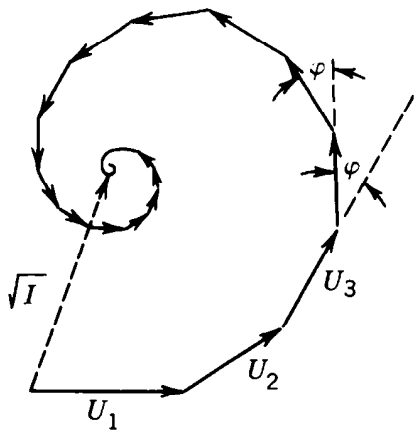



# Fabry Perot Interferometer

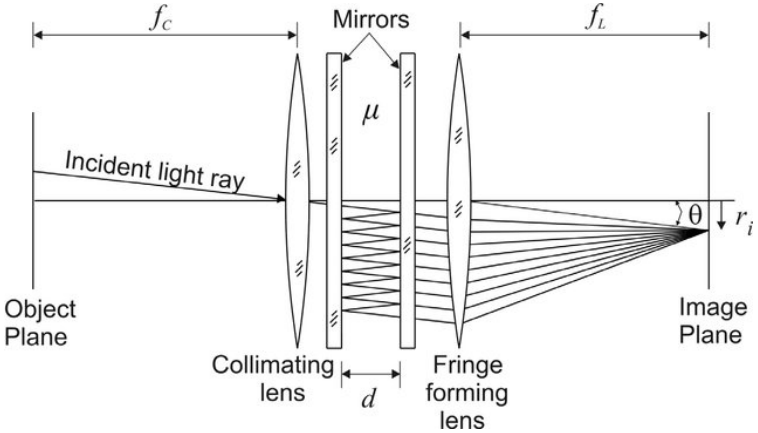
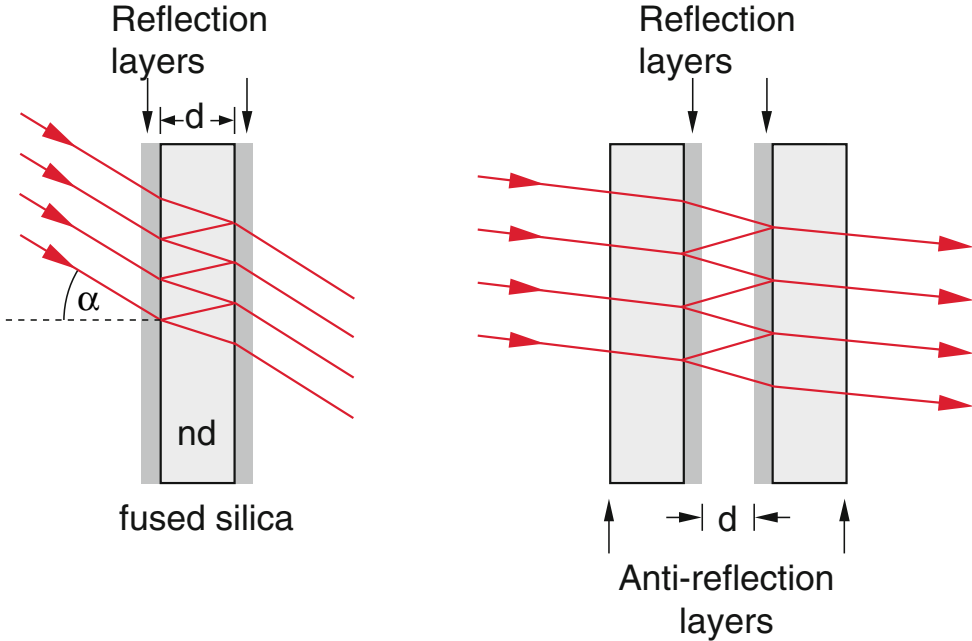

# Fabry Perot Interferometer

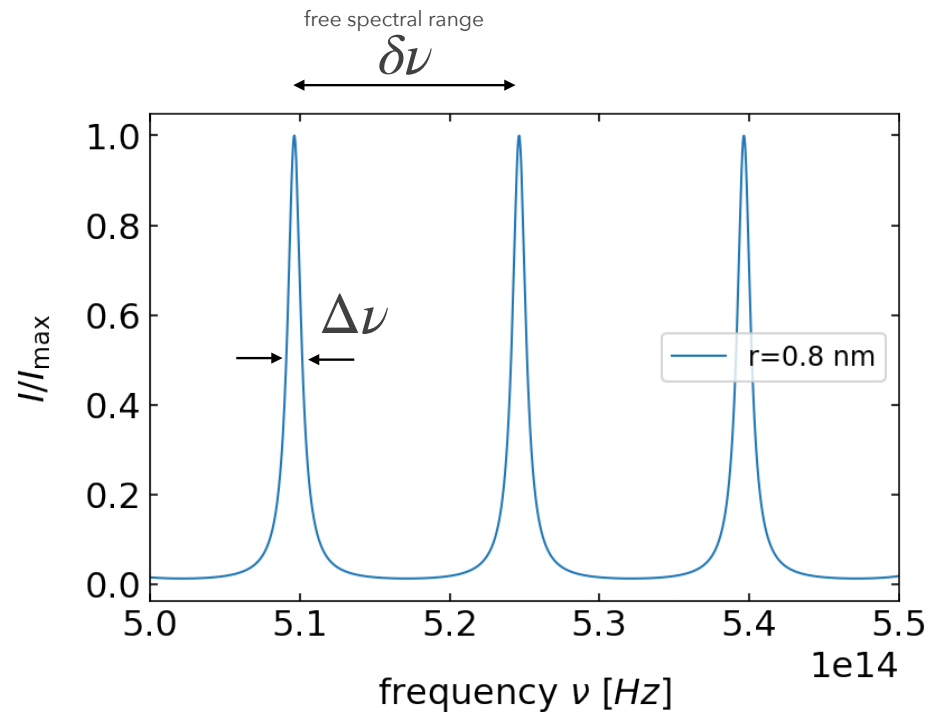
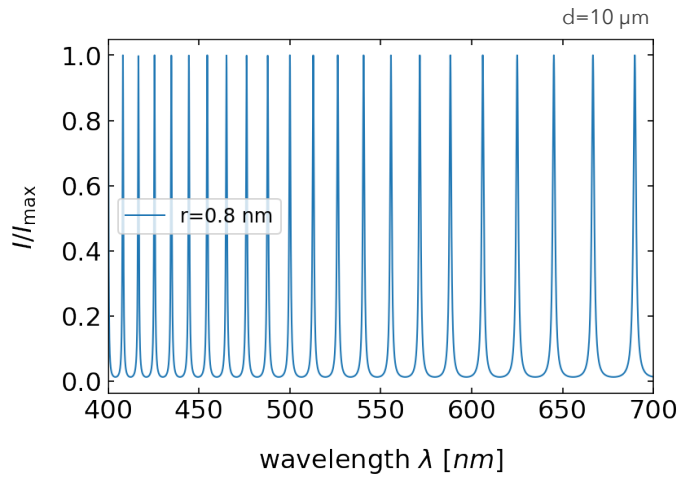
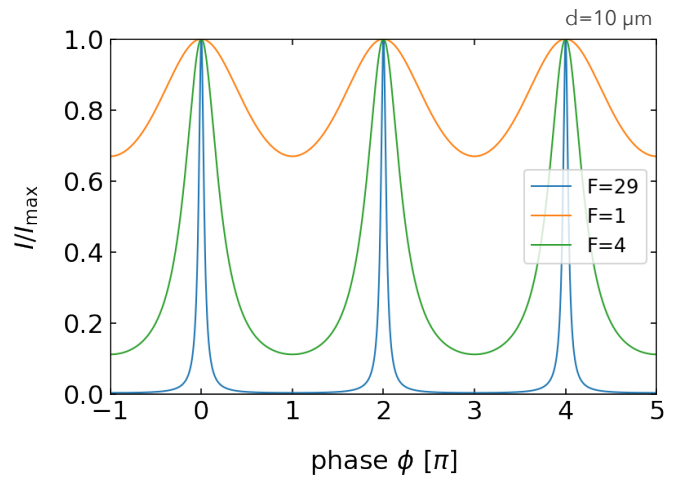

$$\mathcal{F} = \frac{\delta\nu}{\Delta\nu}$$

# Applications - Dielectric Mirrors

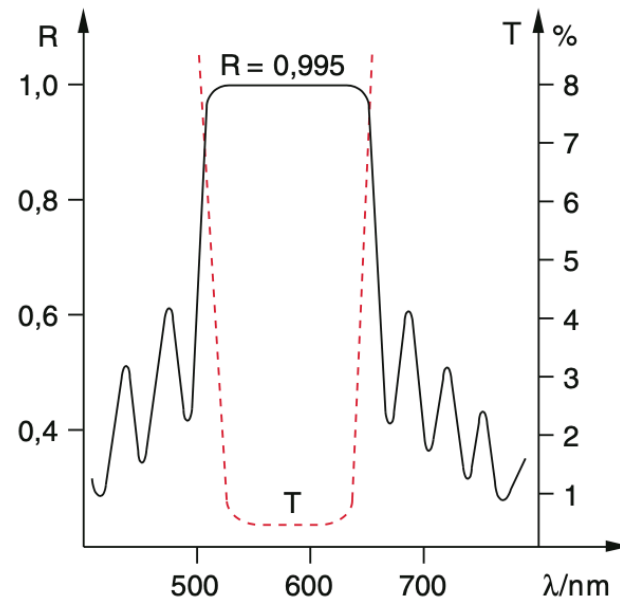
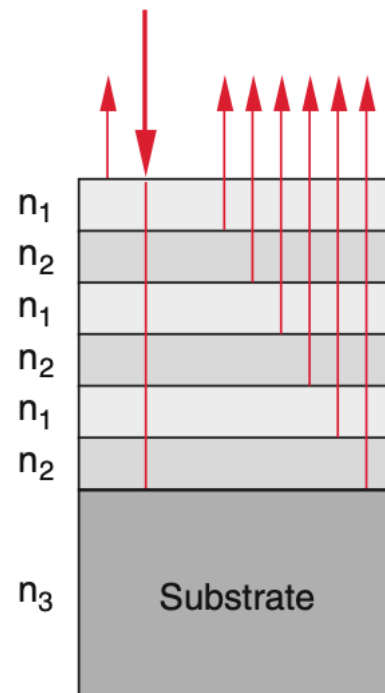

# Anti-reflection Coating

